

**INSTALLATION AND OPERATIONS
MANUAL**
MODEL 890-1500 for INLINE INSTALLATIONS



Will never reduce suction, even if filled to over-capacity!

211 Grover Street, Lynden, WA 98264 Tel 800-817-6704
www.amalgamseparation.com
info@amalgamseparation.com

LEAVE THIS MANUAL ON-SITE FOR FUTURE REFERENCE

MASTER ASSEMBLY NOTES



Right-hand installation
(as shipped)



Left-hand installation

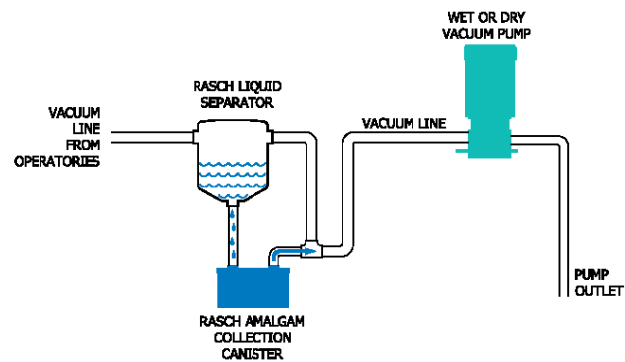

SPECIFICATIONS

Height 22"
Depth 10.25"
Width 17"
Weight 19 Lbs (empty)

Model 890-1500 Amalgam Separator

The separator consists of three primary components:

- 1) A Yellow Buffer Tank which separates fluids and solids from the waste-stream and routes them into the Amalgam Collection Canister.
- 2) The Amalgam Collection Canister separates amalgam through the combined processes of sedimentation, filtration, and ion-exchange. An inlet port receives untreated fluid from the yellow buffer tank, and treated fluid is routed back into the main suction system.
- 3) The racking system, designed to wall or floor mount, provides support to both the Yellow Buffer Tank and the Amalgam Collection Canister.

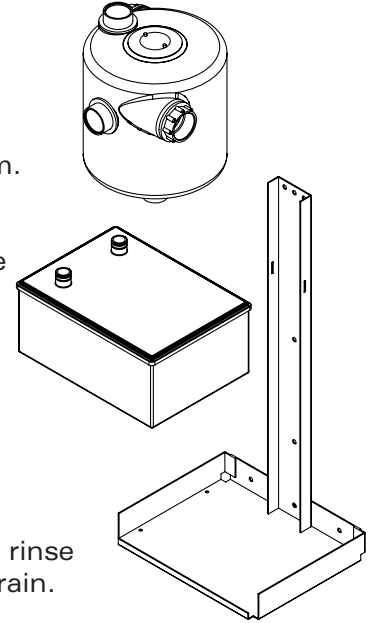

PRE-INSTALLATION NOTES

- √ Consideration should be given to converting continuous rinse cuspidors to timed rinse, and gravity drain to vacuum drain.
- √ Air abrasion will reduce canister life of all amalgam separators. Please take this into consideration when determining replacement schedule of the canister.

CAUTIONS

The Rasch System 890 is designed to be placed directly on the floor. Where floor space is at a premium, it may be mounted on a sturdy wall capable of supporting 100 lbs. Use all provided holes when fastening the bracket to the wall.

Prior to installation, review the condition of the existing hoses and tubing. Replace any which are cracked or show signs of leakage or deterioration. Use silicone sealant when connecting spirallock hose to barbed fittings. Use teflon tape on all threaded fittings.

Do not attempt to open amalgam canisters. Used canisters may contain silver, mercury, metal amalgams and bio-toxins that may be hazardous to your health. Spills of contents should be handled in accordance with HAZMAT procedures.

Dispose of used canisters only by following shipping instructions provided with replacement canisters.

INSTALLATION STEPS

Select an installation site directly on the floor or on a wall that will support 100 pounds. Refer to the information provided in Pre-Installation Notes and Cautions and diagrams. Note that separators inlet and outlet may be swapped right - left before installation. See "Master Assembly Notes".

Locate the "Drop-tube" and install it into the outlet port on either of the top/sides of the Yellow buffer tank. This is a pre-fit only - it will be glued in proper position later.



Drop-tube assembly



Drop-tube pre-fit

Place the gray amalgam collection canister onto the frame. Apply silicone o-ring lube (Parker O-Lube or equivalent) to the inlet and outlet o-rings. Locate the Drain Tube, and connect its and the Transfer Tubes adaptors onto the canister by pushing down with a twisting motion. Caution: Ensure the lock screws on the side of the adaptors are either removed, or backed out so as not to tear the o-rings during insertion. Twist lock-screws into place carefully. Screws need only to engage with recessed groove to prevent fitting from sliding up.



Lube fittings



Drain tube assembly



Back out lock screws

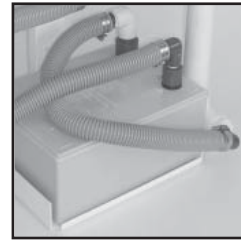

Install adaptors onto canister

Locate the white PVC slip-fitting on the loose end of the drain-tube. Slip it into the front port of the bottom of the drop-tube.



Drain tube PVC Slip-fitting



Slip-fitting inserted



Drain tube installed



Thread in lock screws

If required, the optional 890-5500 Alarm Sensor may be inserted at this time. (See separate instructions provided with alarm)

Find a location between the operatories and suction pump where it would be suitable to cut the main suction line. **DO NOT CUT THE LINE AT THIS TIME!**

Measure the main suction line piping and choose PVC fittings that will allow you to interface with the inlet and the outlet ports of the Amalgam separator. This system is designed to accept 1-1/2" PVC or flex tubing. Avoid using any fittings or connections smaller than 1-1/4" so air flows freely.

Hold the Amalgam Separator white frame in a suitable position and ensure that there is adequate room for the installation. If wall mounting, secure the frame in place with appropriate fasteners using at least 6 of the existing mounting holes to provide adequate support.

Rotate the drop-tube in the elbow to a suitable position where the outlet port will point towards the suction pump location and interface with the suction line leading to the suction pump. **You may now glue the Drop-tube in place.**

Refer to right and left hand "Master Assembly" photos for an overview to ensure that separator can be installed as intended.

Turn off the electrical power supply to the clinic suction system and ensure that the suction lines are empty.

Cut the main suction line and trim/modify to allow connection to inlet and outlet of amalgam separator. Glue any remaining fittings previously test-fitted. Make flex or hard PVC connections to the inlet and outlet of the Amalgam Separator. Flex is recommended where possible for ease of installation.

Remove inlet/outlet hoses and slowly fill the canister with tap-water to the following procedure;

- a) Fill canister with cool tapwater. A funnel is provided for your convenience
- b) Stand canister on end with inlet/outlet on top and vibrate to release air bubbles.
- c) Top-up with water and replace canister inlet/outlet hoses.

RED Decals in the bagged parts kit are provided as reminders for canister exchange. Determine when each canister should be exchanged (see below), peel the appropriate month and year from the decal and stick on the canister. Place another decal on the doctor's appointment calendar and make a note for the salesman to call back at that time as a courtesy.

The Rasch 890-1500 system has one canister and will last on average 18 months in a typical office.

WARRANTY

This unit is Warranted against defects in material and workmanship for a period of five years. Warranty claims must be made directly to AB DENTAL TRENDS INC. 211 Grover St, Lynden, WA 98264 Tel: 360-354-4722 Fax: 360-354-7460

TECHNICAL SERVICE

Installation Assistance is available at no charge by calling 1-800-817-6704 or 360-354-4722 and asking for
Amalgam Separation Technical Assistance.

Hours are 8 am to 5 p.m. Pacific Time. Fax is 1-800-817-6705 or 360-354-7460. E-mail info@amalgamseparation.com

AMALGAM SEPARATOR OPERATION GUIDELINES

REGULATORY

AB Dental Trends Inc. strongly suggests contacting the ADA and obtaining and incorporating into the practice their Best Management Practices (BMP's).

Ensure all state and local regulations and codes are adhered to.

MAINTENANCE

Flush suction lines daily with an appropriate (see notes below) cleanser. Proper suction-line cleaning protocol is imperative when amalgam separators are installed as a separator provides an environment conducive to algae and bacteria growth when idle. Excessive colonies of micro-organisms may restrict flow.

Step 1 - Aspirate one to two gallons of warm water through the vacuum valve furthest from the pump.

Step 2 - Following the cleanser directions, aspirate the recommended mixture (usually one quart/liter) through each of the vacuum valves. Ensure that each valve draws air before closing and replacing into the hanger.

FOLLOW A DAILY PROTOCOL FOR CLEANING SUCTION LINES

Desirable characteristics of evacuation line cleaners:

1. Detergent action to break up and move solid materials.
2. Neutral pH. Acids and bleach may liberate mercury from amalgam.
3. Non-foaming or low-foaming. Foam may reduce efficiency of pumps and amalgam separators.

Instrument soaking cleaners and are not effective for line cleaning.

Ensure that Amalgam Separator canisters are replaced in accordance with the dated red decal applied to the outside.

If an alarm is installed, ensure that the battery is replaced and the alarm function is tested annually.