

RASCH AMALGAM SEPARATORS

FIELD PROVEN - FIELD TOUGH

Rasch has been marketing amalgam separation systems worldwide since 1987. The design was initially developed for the European market, and has been refined over time to provide trouble-free world-wide operation. Other models, each using the same Rasch amalgam separator canister, are offered to facilitate specific types of installations.

AB Dental Trends Amalgam Separation, providing the broadest coverage and support for North America.

890-6000

DRY PUMP OUTLET SYSTEM

- Lowest monthly AND 5 year cost on the market
- Attaches to the outlet of the pump collector tank
- Large facilities may use a simple manifold for the desired number of canisters to accommodate multiple doctors and higher flow rates
- Lowest monthly AND 5 year cost on the market
- Certified to exceed the ISO 11143 test protocol at over 99%
- High max thru-put of 4 liters per minute
- Quick change of canisters
- Cuspidsors easily handled
- Small footprint for tight spaces
- Recycling & return shipping is included
- Each canister lasts 18 months
- 5 year warranty



890-6000

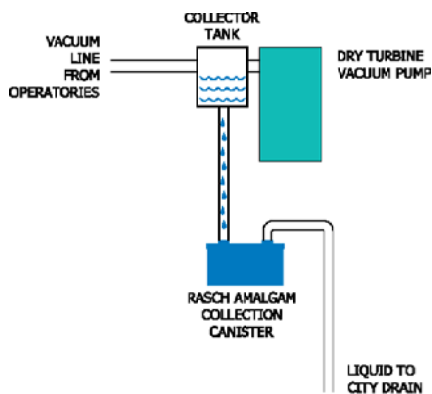

INSTALLED ON DRAIN OF DRY PUMP



- Modular design allows for manifolding to accommodate large facilities
- Durable molded Polymer withstands impact and extreme temperature fluctuations

AB AB Dental Trends
DT We make problems go away

W PARTS WAREHOUSE
Let us be your dental resource

211 Grover Street
Lynden, Washington
USA 98264

Toll-Free: 1-800-817-6704
Local Tel: (360) 354-4722
Local Fax: (360) 354-7460

See www.amalgamseparation.com or call 1-800-817-6704 for pricing and additional information.